

FLAME ARRESTER Section 2.3

EXPLOSION PROOF IN-LINE FLAME ARRESTER

KSFL TYPE FLAME ARRESTER



Benefits

- Meet USCG, IMO MSC/Circ,677 & EN 12874 requirements
- Designed for Explosion & Deflagration proof
- Maximum Capacity & Minimum Pressure drop
- Capability of Bi-directional flow & flame arresting
- Quick & Easy removable element
- Very easy cleaning & maintenance
- Available vertical & horizontal installation
- High quality corrosion & chemical resistance
- Useful for vapor mixed line

Introduction

The model KSFL inline flame arrester is designed, manufactured and tested according to API2000 and British Standard Specification Code BS 7244 and EN 12874.

The unit are passive devices with no moving parts.

The KSFL deflagration flame arresters provide protection against flame propagation in piping systems that are manifolded or have long runs.

The arresters are designed to stop an ignited flammable vapor mixture travelling at subsonic vapor velocities.

They are also designed to protect against continuous burning against the 316LSS flame cell for a specific period.

The standard flame cell is suitable for NEC group D or IEC IIA gases. Cells for other gas groups are available as additional extras.

The flame arresters are available with either carbon steel (epoxy coated), 304SS, or 316SS housing with 316LSS flame cells.

Sizes range from 25mm to 600mm.

Standard flanges are ANSI 150lb and other connections are available upon request.

FLAME ARRESTER Section 2.3

EXPLOSION PROOF IN-LINE FLAME ARRESTER

KSFL TYPE FLAME ARRESTER

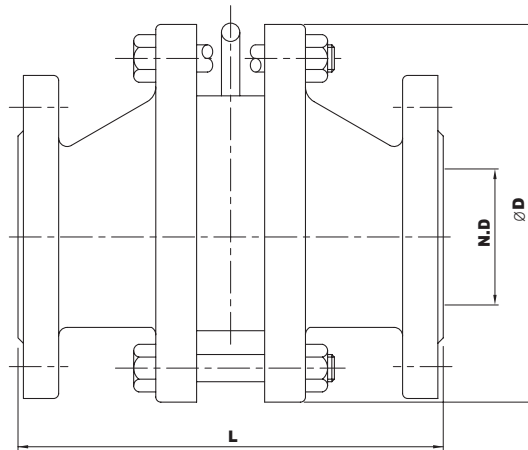

Dimension Table

Unit = mm

Size	2"	3"	4"	6"	8"	10"	12"	Other Size
N.D	50	80	100	150	200	250	300	Available on request
ØD	210	250	275	385	450	600	680	
L	250	270	278	335	353	377	565	

Note: Standard Connection: ANSI 150LB FF FLANGE, JIS or different sizes available on request.

Materials of Construction

	Standard Design	Special Design	
Body	C.I	Cast C.S	S.S & AL
Element Ring	C.S or S.S	C.S or S.S	S.S
Element	Aluminium or Stainless Steel		
Standard Coating	In-Out side Epoxy 250 Micron except for S.S & AL Part.		

Note : C.I - Cast Iron, S.S - Stainless Steel, C.S - Carbon Steel, AL - Aluminium